

**20' AUTOLOC SPREADER, WLL 70,528 LB. (N31000C-1PA)**  
**Cage Code: 65059 | Drawing No: SN31000C | Revision: A | Sheet: 1 of 2**

UNLESS OTHERWISE SPECIFIED, DIMENSIONS ARE IN INCHES

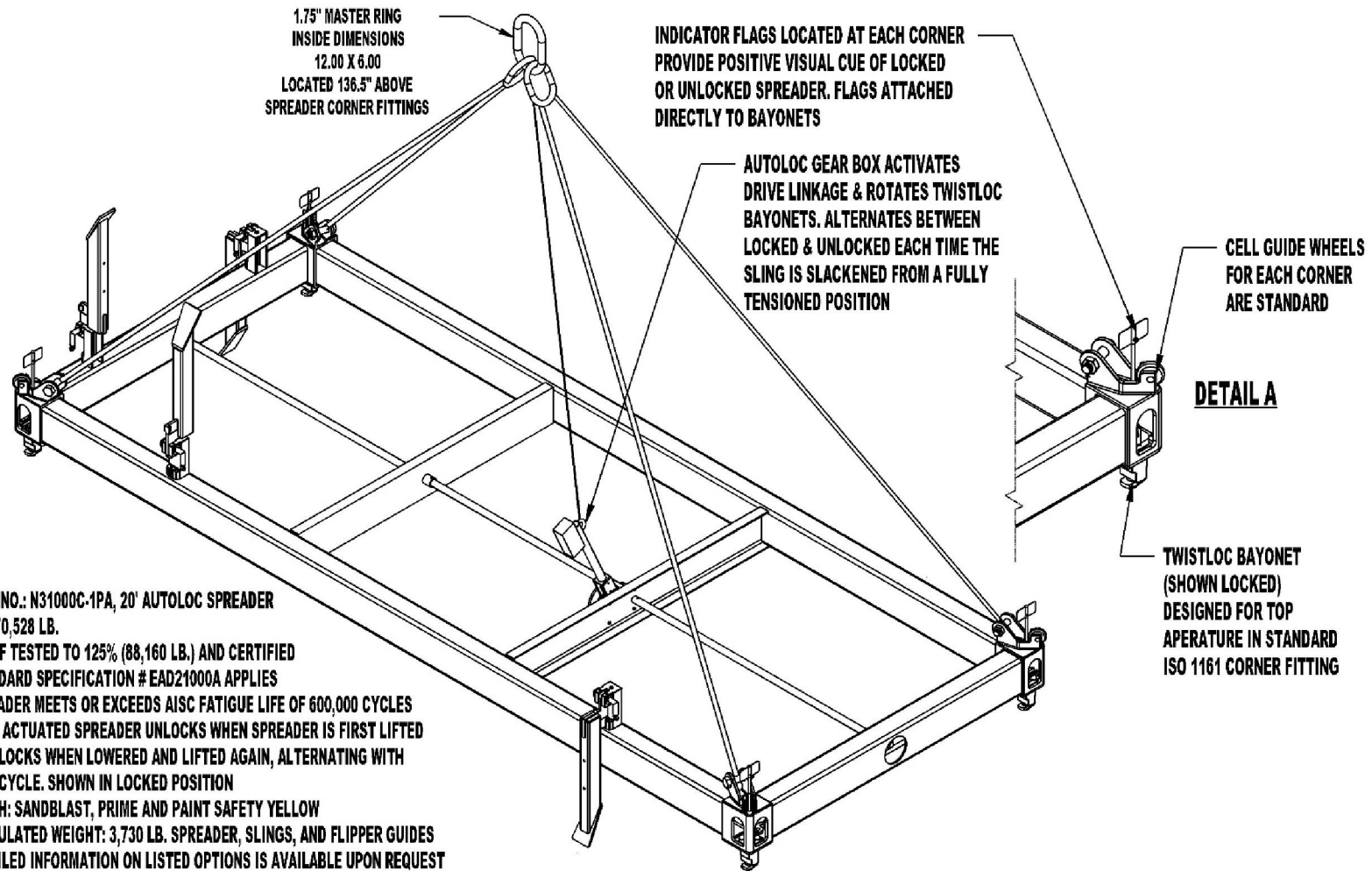

**NOTES:**

1. PART NO.: N31000C-1PA, 20' AUTOLOC SPREADER
2. WLL 70,528 LB.
3. PROOF TESTED TO 125% (88,160 LB.) AND CERTIFIED
4. STANDARD SPECIFICATION # EAD21000A APPLIES
5. SPREADER MEETS OR EXCEEDS AISC FATIGUE LIFE OF 600,000 CYCLES
6. AUTO ACTUATED SPREADER UNLOCKS WHEN SPREADER IS FIRST LIFTED THEN LOCKS WHEN LOWERED AND LIFTED AGAIN, ALTERNATING WITH EACH CYCLE. SHOWN IN LOCKED POSITION
7. FINISH: SANDBLAST, PRIME AND PAINT SAFETY YELLOW
8. CALCULATED WEIGHT: 3,730 LB. SPREADER, SLINGS, AND FLIPPER GUIDES
9. DETAILED INFORMATION ON LISTED OPTIONS IS AVAILABLE UPON REQUEST

To avoid lifter failure, potential death and property damage, never exceed WLL (Working Load Limit).

This document contains the proprietary information of Tandemloc, Inc. and your access and use shall be, and is at all times, pursuant to and limited by the Tandemloc, Inc. Terms of Use.

You shall not, and shall not encourage, assist, or authorize another party to copy, distribute, publicly display, modify, reverse engineer, decompile, or take any other action to reproduce this document or the information contained herein. © Copyright 2014 by Tandemloc, Inc.

Dimensions are subject to manufacturing tolerance and change.



Email: [info@tandemloc.com](mailto:info@tandemloc.com) • [www.tandemloc.com](http://www.tandemloc.com)

824 Highway 101 • Havelock, NC 28532

Tel: 1.800.258.7324 (252.447.7155)

FAX 1.800.892.3273 (252.447.5502)

Tandemloc, Inc. designs, manufactures and tests lifting, securing and mobilizing components for all industries. See our website for details and important safety information.

Read all safety labels and instructions prior to use. Product to be used by qualified personnel only.

## 20' AUTOLOC SPREADER, WLL 70,528 LB. (N31000C-1PA)

Cage Code: 65059 | Drawing No: SN31000C | Revision: A | Sheet: 2 of 2

UNLESS OTHERWISE SPECIFIED, DIMENSIONS ARE IN INCHES

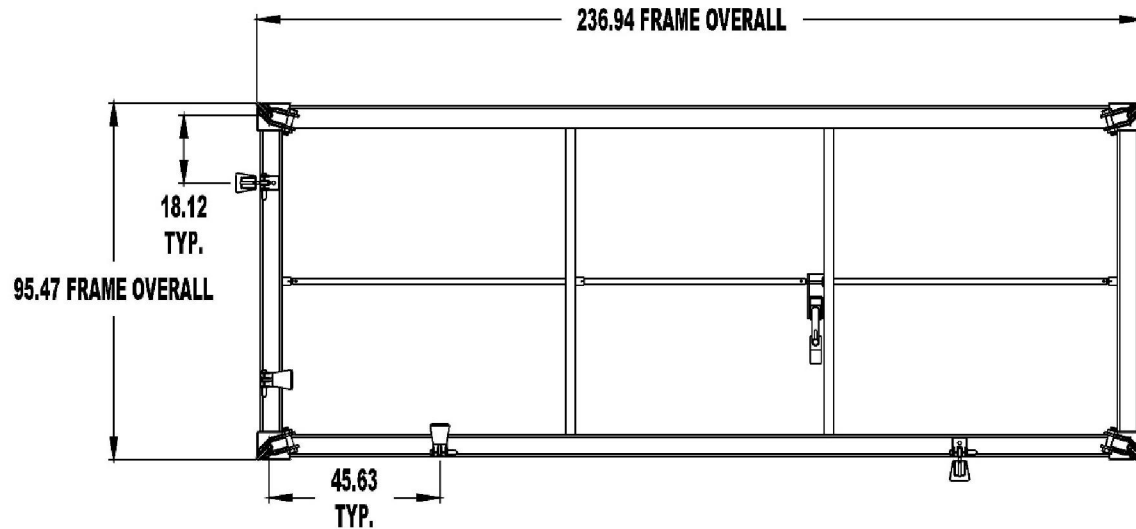

### NOTES:

1. PART NO.: N31000C-1PA, 20' AUTOLOC SPREADER
2. OUTSIDE DIMENSIONS OF SPREADER (LENGTH AND WIDTH) LESS THAN OUTSIDE DIMENSIONS OF LIFTED CONTAINER

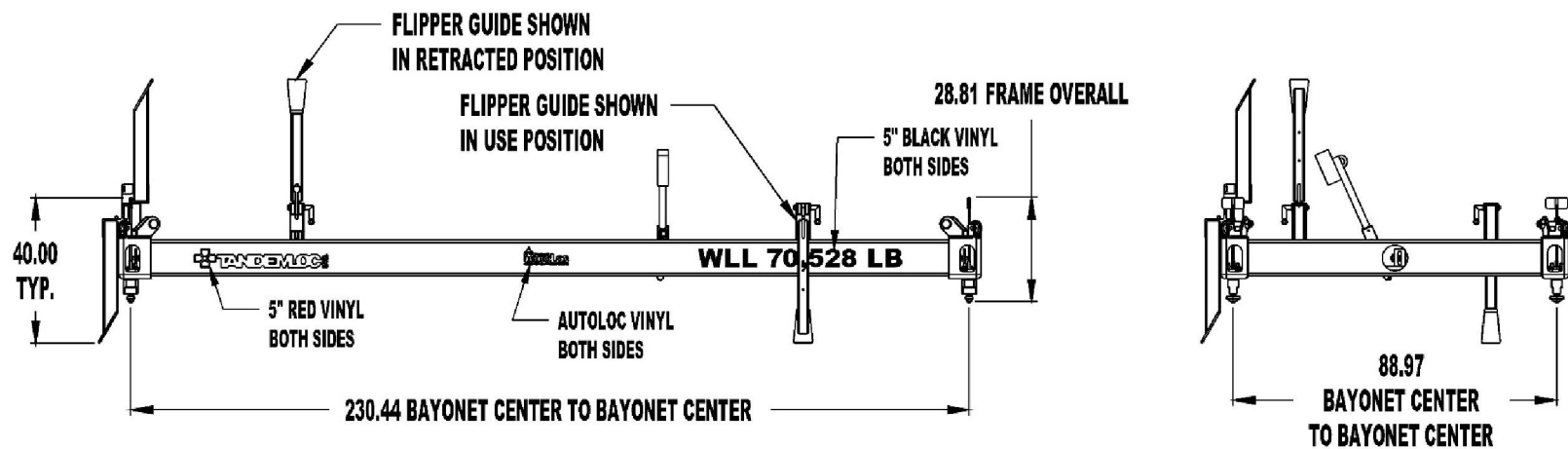

To avoid lifter failure, potential death and property damage, never exceed WLL (Working Load Limit).

This document contains the proprietary information of Tandemloc, Inc. and your access and use shall be, and is at all times, pursuant to and limited by the Tandemloc, Inc. Terms of Use.

You shall not, and shall not encourage, assist, or authorize another party to copy, distribute, publicly display, modify, reverse engineer, decompile, or take any other action to reproduce this document or the information contained herein. © Copyright 2014 by Tandemloc, Inc.

Dimensions are subject to manufacturing tolerance and change.



Email: [info@tandemloc.com](mailto:info@tandemloc.com) • [www.tandemloc.com](http://www.tandemloc.com)

824 Highway 101 • Havelock, NC 28532

Tel: 1.800.258.7324 (252.447.7155)

FAX 1.800.892.3273 (252.447.5502)

Tandemloc, Inc. designs, manufactures and tests lifting, securing and mobilizing components for all industries. See our website for details and important safety information.

Read all safety labels and instructions prior to use. Product to be used by qualified personnel only.

# 40' AUTOLOC SPREADER, WLL 67,200 LB. (N3100AA-2PA)

Cage Code: 65059 | Drawing No: SN3100AA-2PA | Revision: D | Sheet: 1 of 2

UNLESS OTHERWISE SPECIFIED, DIMENSIONS ARE IN INCHES

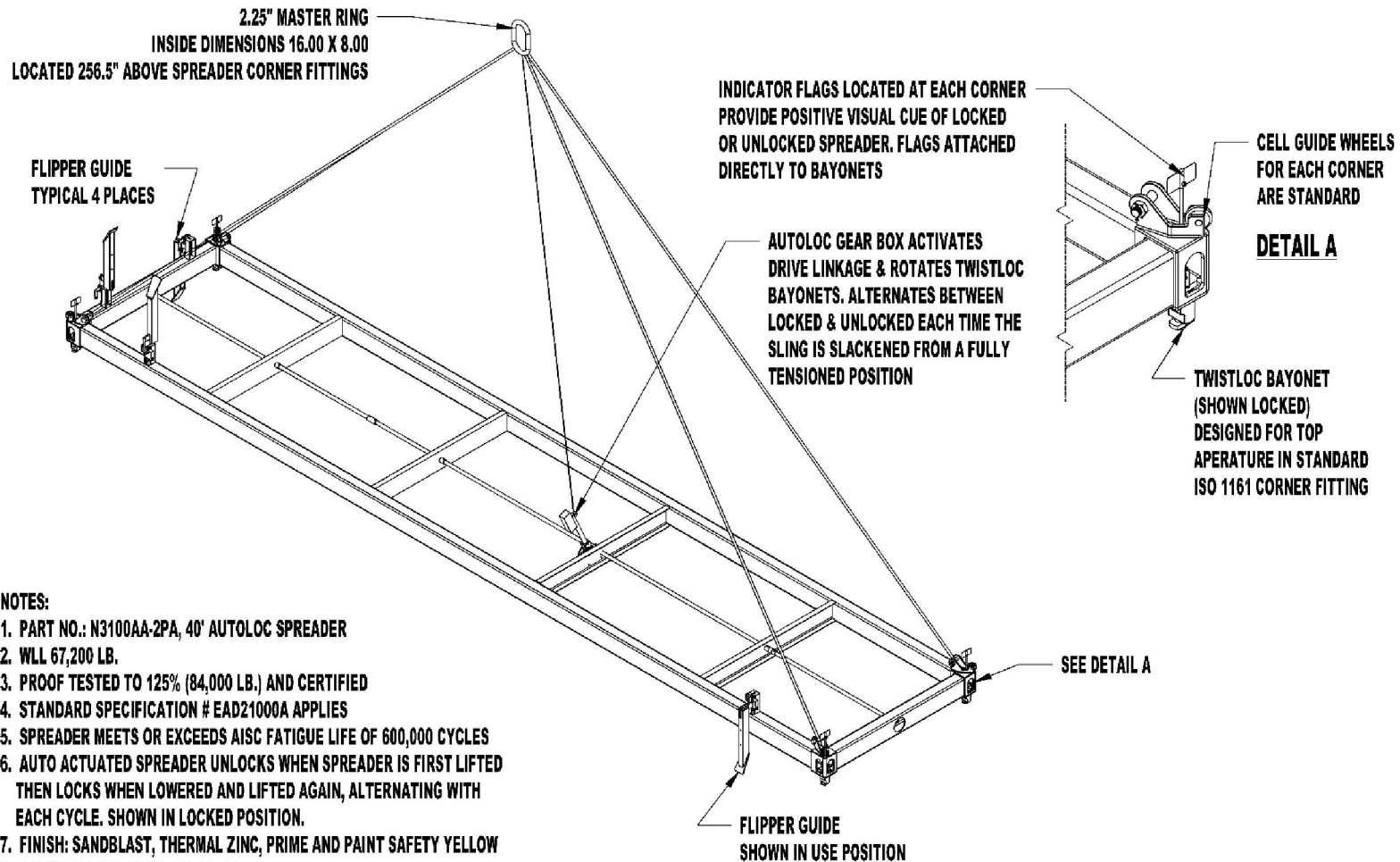

## NOTES:

1. PART NO.: N3100AA-2PA, 40' AUTOLOC SPREADER
2. WLL 67,200 LB.
3. PROOF TESTED TO 125% (84,000 LB.) AND CERTIFIED
4. STANDARD SPECIFICATION # EAD21000A APPLIES
5. SPREADER MEETS OR EXCEEDS AISC FATIGUE LIFE OF 600,000 CYCLES
6. AUTO ACTUATED SPREADER UNLOCKS WHEN SPREADER IS FIRST LIFTED THEN LOCKS WHEN LOWERED AND LIFTED AGAIN, ALTERNATING WITH EACH CYCLE. SHOWN IN LOCKED POSITION.
7. FINISH: SANDBLAST, THERMAL ZINC, PRIME AND PAINT SAFETY YELLOW
8. CALCULATED WEIGHT: 4,975 LB.
9. DETAILED INFORMATION ON LISTED OPTIONS IS AVAILABLE UPON REQUEST

To avoid lifter failure, potential death and property damage, never exceed WLL (Working Load Limit).

This document contains the proprietary information of Tandemloc, Inc. and your access and use shall be, and is at all times, pursuant to and limited by the Tandemloc, Inc. Terms of Use.

You shall not, and shall not encourage, assist, or authorize another party to copy, distribute, publicly display, modify, reverse engineer, decompile, or take any other action to reproduce this document or the information contained herein. © Copyright 2014 by Tandemloc, Inc.

Dimensions are subject to manufacturing tolerance and change.



Email: [info@tandemloc.com](mailto:info@tandemloc.com) • [www.tandemloc.com](http://www.tandemloc.com)

824 Highway 101 • Havelock, NC 28532

Tel: 1.800.258.7324 (252.447.7155)

FAX 1.800.892.3273 (252.447.5502)

Tandemloc, Inc. designs, manufactures and tests lifting, securing and mobilizing components for all industries. See our website for details and important safety information.

Read all safety labels and instructions prior to use. Product to be used by qualified personnel only.

# 40' AUTOLOC SPREADER, WLL 67,200 LB. (N3100AA-2PA)

Cage Code: 65059 | Drawing No: SN3100AA-2PA | Revision: D | Sheet: 2 of 2

UNLESS OTHERWISE SPECIFIED, DIMENSIONS ARE IN INCHES

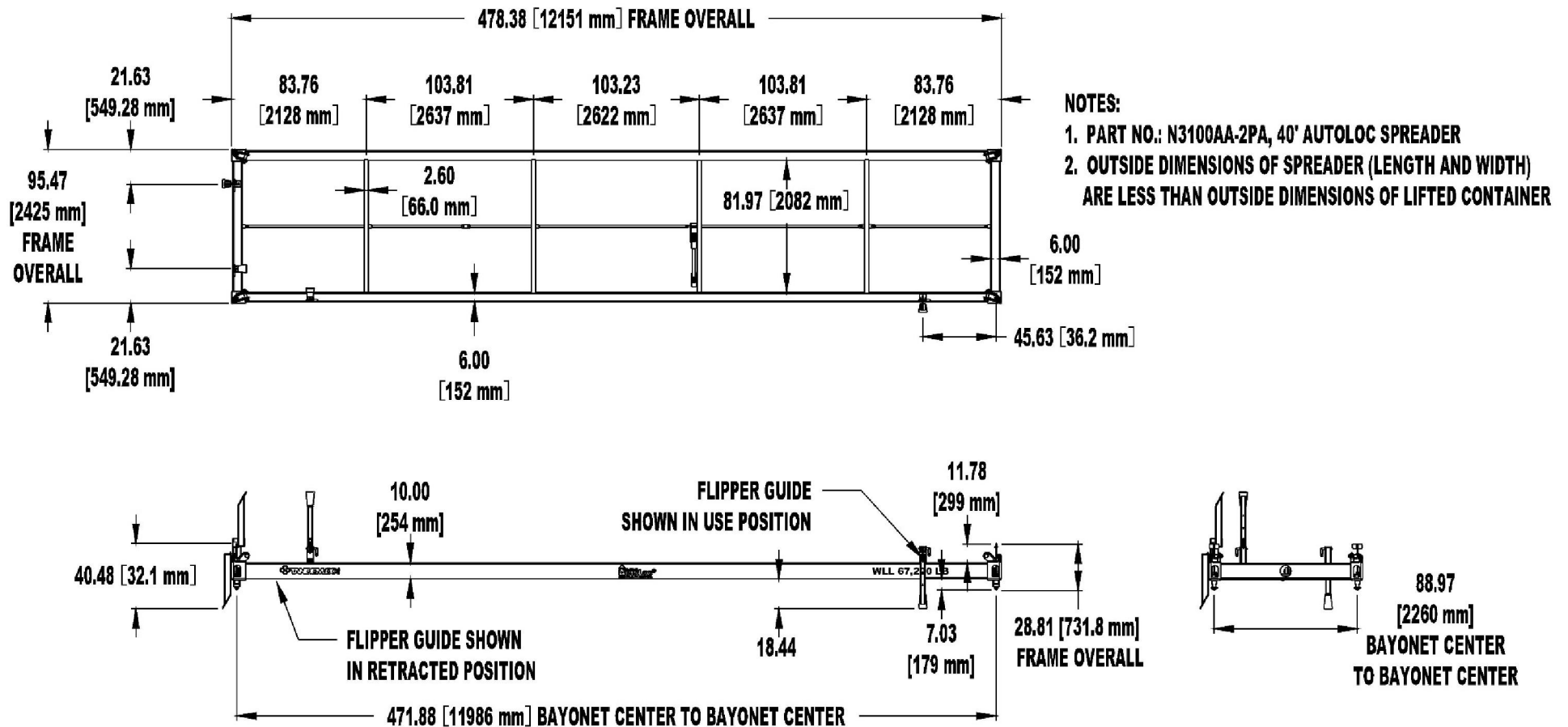

To avoid lifter failure, potential death and property damage, never exceed WLL (Working Load Limit).

This document contains the proprietary information of Tandemloc, Inc. and your access and use shall be, and is at all times, pursuant to and limited by the Tandemloc, Inc. Terms of Use.

You shall not, and shall not encourage, assist, or authorize another party to copy, distribute, publicly display, modify, reverse engineer, decompile, or take any other action to reproduce this document or the information contained herein. © Copyright 2014 by Tandemloc, Inc.

Dimensions are subject to manufacturing tolerance and change.



Email: [info@tandemloc.com](mailto:info@tandemloc.com) • [www.tandemloc.com](http://www.tandemloc.com)

824 Highway 101 • Havelock, NC 28532

Tel: 1.800.258.7324 (252.447.7155)

FAX 1.800.892.3273 (252.447.5502)

Tandemloc, Inc. designs, manufactures and tests lifting, securing and mobilizing components for all industries. See our website for details and important safety information.

Read all safety labels and instructions prior to use. Product to be used by qualified personnel only.