

This document contains the proprietary information of Tandemloc, Inc. and your access and use shall be, and is at all times, pursuant to and limited by the Tandemloc, Inc. Terms of Use. You shall not, and shall not encourage, assist, or authorize another party to copy, distribute, publicly display, modify, reverse engineer, decompile, or take any other action to reproduce this document or the information contained herein.

©2024 by Tandemloc, Inc.  
Dimensions are subject to manufacturing tolerance and change.

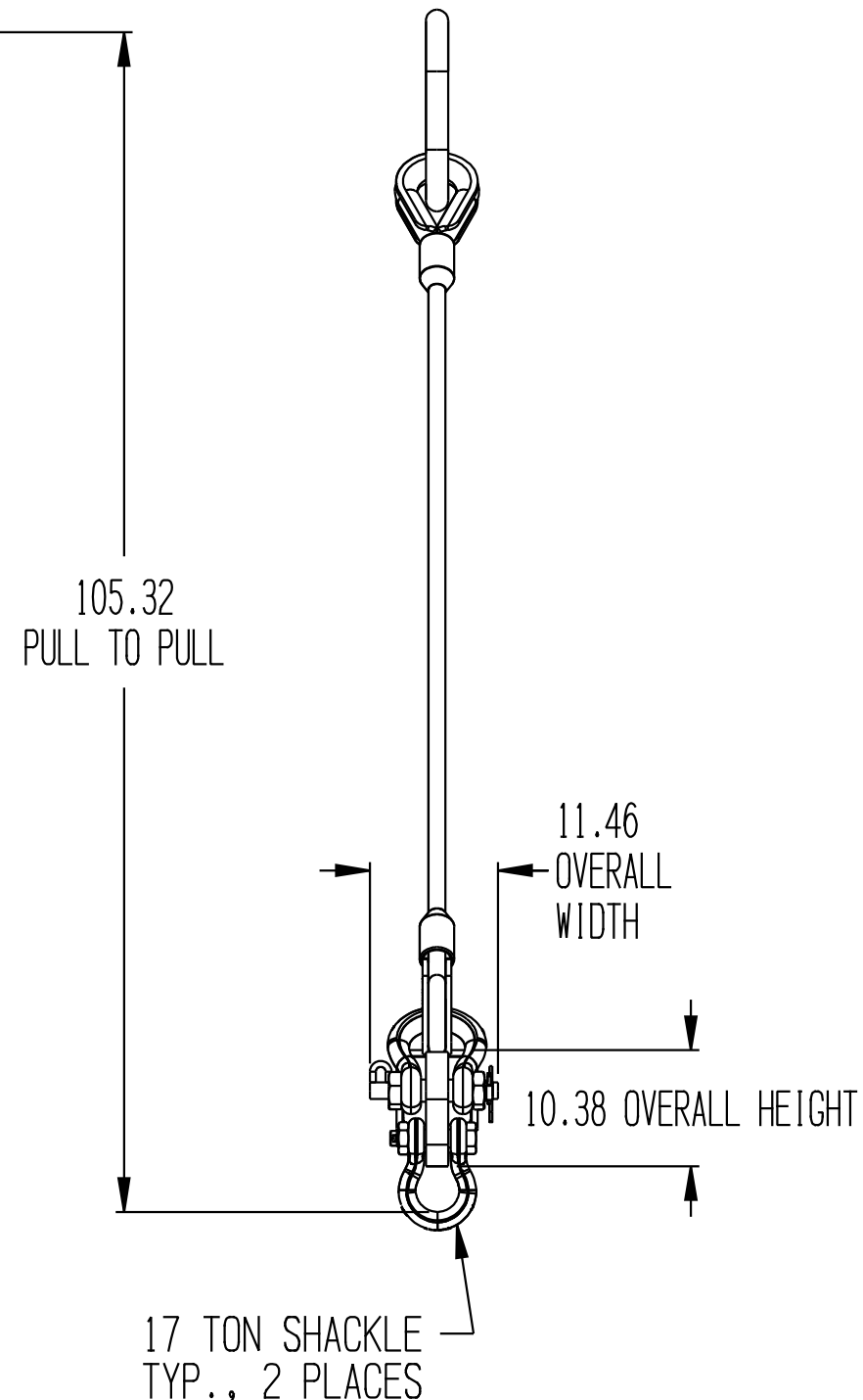
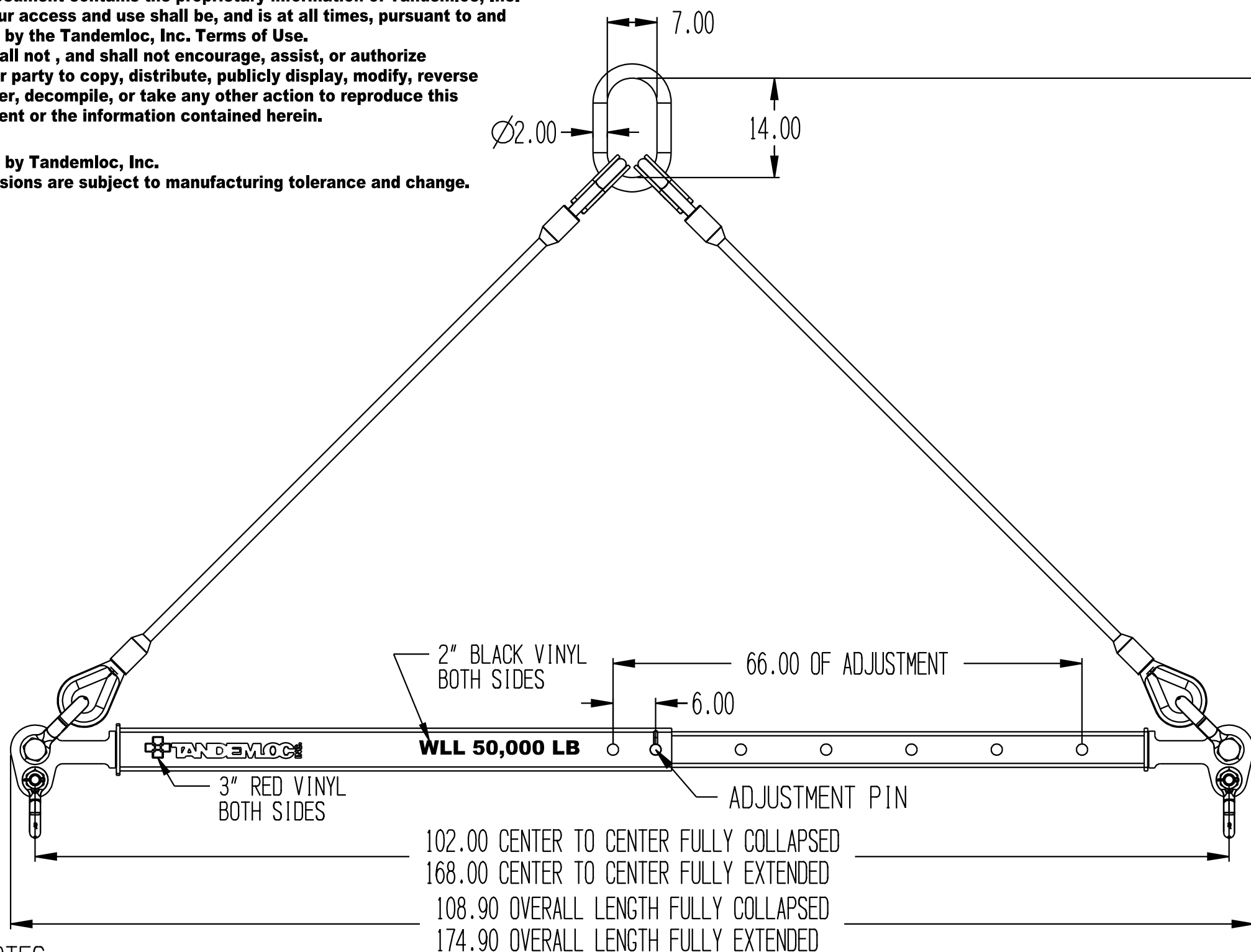

NOTES:

- PART NO.: AT14A050-168-PA, 102"-168" TELESCOPIC SPREADER  
AT14A050-168SPA, 102"-168" TELESCOPIC SPREADER WITH TOP SLING  
AT14A050-168WPA, 102"-168" TELESCOPIC SPREADER WITHOUT SHACKLES
- WLL: 50,000 LB. @ 45° MINIMUM
- PROOF TESTED TO 125% (62,500 LB.) AND CERTIFIED
- STANDARD SPECIFICATION # EAD21000A APPLIES
- FINISH: SANDBLAST AND PRIME AND PAINT YELLOW
- CALCULATED WEIGHT: W/OUT SHACKLES: 433 LB. W/ SHACKLES 439 LB. SPREADER WITH SLING: 745 LB.
- DESIGNED AND MANUFACTURED TO MEET OR EXCEED ASME B30.20 AND BTH-1, DESIGN CATEGORY B, SERVICE CLASS 0.

REVISIONS			
REV	DESCRIPTION	DATE	APPROVED

**\*\* DO NOT SIGN IF CHANGES ARE REQUIRED \*\***

CUSTOMER APPROVAL: \_\_\_\_\_

DATE: \_\_\_\_\_

<small>                 [X] *X* DENOTES APPLICABLE DATA UNLESS OTHERWISE NOTED, DIMENSIONS ARE IN INCHES &amp; TOLERANCES ARE:                  .XX ±.06 .XXX ±.0007                  .XXX ±.03             </small>	<small>                 [ ] *X* DENOTES APPLICABLE DATA LOST MAX CASTING TOL. IS:                  0 TO 4" ±.030 , 4.01" TO 7" ±.038"                  7.01" TO 10.5" ±.045"                  OVER 10.5" ±.052"             </small>		
		TITLE AT14A050-168-PA 102"-168" TELESCOPIC SPREADER	
<small>                 THIS DOCUMENT CONTAINS DATA WHICH IS EITHER PATENTED, PATENT PENDING OR IS THE PROPERTY OF TANDEMLOC, INC. DISCLOSURE, OR COPYING WITHOUT THE WRITTEN AUTHORIZATION OF TANDEMLOC, INC. IS EXPRESSLY PROHIBITED.             </small>	APPROVALS DRAWN: DAH DATE: 07-31-24	SIZE: D CAGE CODE: 65059 SCALE:	DWG NO.: SAT14A050-168-PA REV. 1 OF 1